

/ Perfect Welding / Solar Energy / Perfect Charging



SHIFTING THE LIMITS

ETR-S ENDLESS TORCH ROTATION SYSTEM

/ TIG hotwire



/ HIGH-END CLADDING SOLUTION

/ Heavy and complex work pieces can be very challenging to the cladding industry. But these challenges are exactly where the ETR system really shines. The FPA 9000 system controller allows precise welding of work pieces with bores and different bore angles. The automatic centering function easily handles bulky work pieces and eliminates time-consuming manual centering processes, dramatically reducing production time and improving quality through precise positioning.

/ HIGHEST THROUGHPUT IN THE INDUSTRY

/ REPEATABLE, CONSISTENT RESULTS

/ STATE-OF-THE-ART WELDING PROCESS PROVIDES INDUSTRY-STANDARD RESULTS

/ VERTICALLY DESIGNED AND MANUFACTURED TO PROVIDE PEAK PERFORMANCE AND EASE OF SERVICE

/ REAL-TIME MONITORING OF ALL WELDING PARAMETERS, LOGGED PER WELDMENT USE



ETR SYSTEM – EVERYTHING FROM A SINGLE SOURCE

/ The entire system is built exclusively with Fronius components, perfectly coordinated to produce excellent welding results. Fronius offers the best technologies available in the cladding market and has established a worldwide technology and market leadership position.

SYSTEM-TECHNOLOGY

/ FULLY DIGITAL

/ REAL-TIME DATA COMMUNICATION

/ FULL PROCESS CONTROL

/ ONE SUPPLY LINE FOR ENTIRE SYSTEM

FCB COLUMN & BOOM

/ Available in different size and travel distances.

CABLE MANAGEMENT

/ Cable routing protected via energy chains.

SYSTEM CONTROLLER

FPA 9000

/ System controller with touch display. A wide range of software features meets the needs of a wide range of applications.

POWER SOURCES SET

/ TransTig 5000 Job and hotwire TransTig 2200 Job.

BASE WITH CARRIAGE (OPTIONAL)

/ The column & boom can be equipped with an optional carriage.

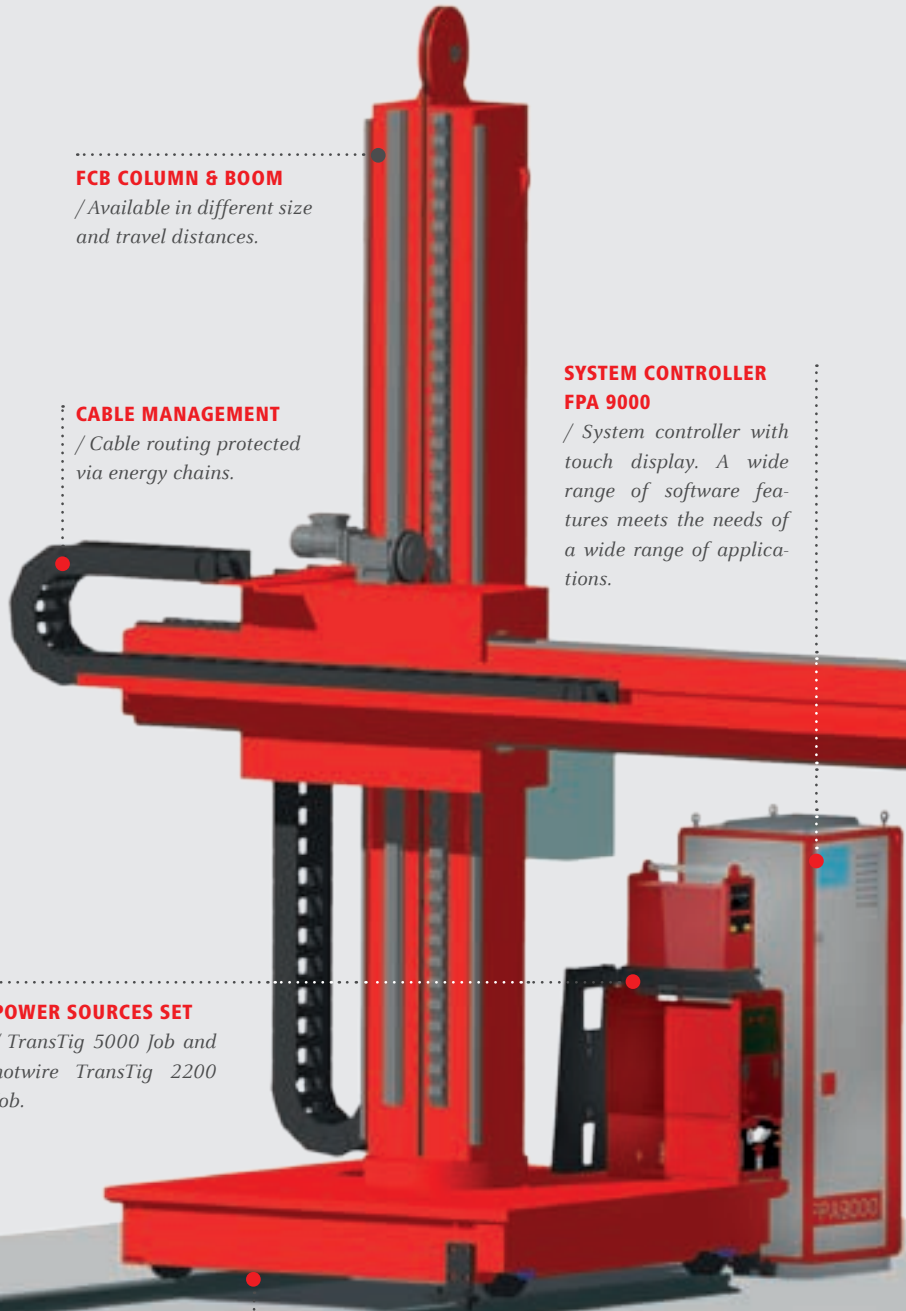

WORK PIECE CENTERING AND GEOMETRY

/ The ETR system delivers the features you need to meet ever-increasing demands for faster setup times and complex work piece geometries.

AUTOMATIC CENTERING

/ Inside centering, outside centering or ring groove centering based on the work piece requirements.

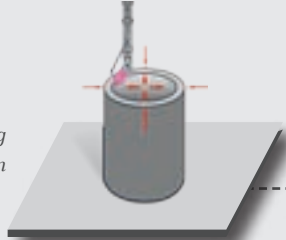

BORE-TO-BORE

/ Intersecting bores are supported as a standard feature.

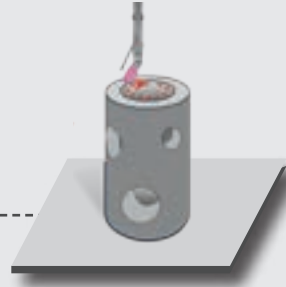

RACE-TRACK

/ „Race-track“ work piece geometries with or without bores are supported as a standard feature.



RECTANGLE (OPTIONAL)

/ The „rectangle“ software function is available as an option.

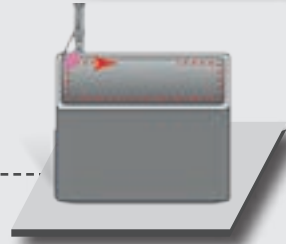

FCS CROSS SLIDE SYSTEM

/ Available with different travel distances.

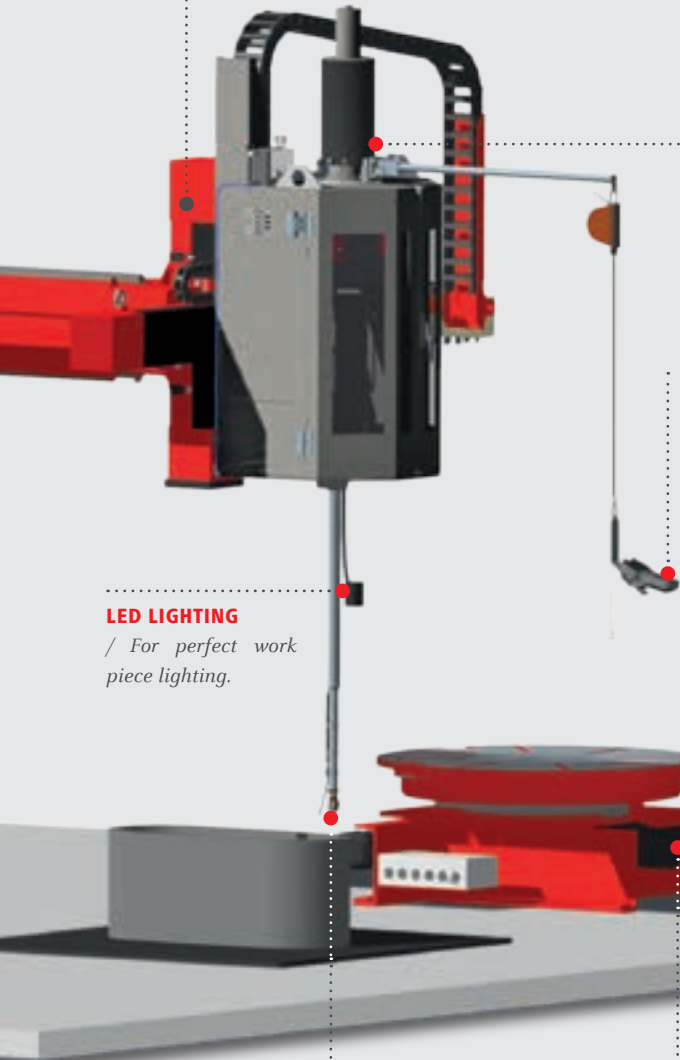

ETR WELDING HEAD

/ The core component of the ETR system is the rotating welding head.

HMI-RC REMOTE CONTROL

/ Remote control with balancer for comfortable hand-held operation.

LED LIGHTING

/ For perfect work piece lighting.

FRT TURNTABLE (OPTIONAL)

/ For special work piece geometries an optional turntable can increase the productivity.

TIG CLADDING TORCH

/ TTHW torches starting at inside diameter 25 mm (1 in).

FPA 9000 SYSTEM CONTROLLER

/ The entire system can be operated through the user-friendly system controller. Equipped with an industry-standard PC and embedded Windows® operating system, the FPA is fully network-compatible and also allows the communication between multiple FPA system controllers. Available internet access enables remote maintenance.

FEATURES

- / 12.1" touch display
- / 3D process visualisation
- / Laser-printer for data documentation
- / Limit-function – actual value display
- / Network-compatible – remote maintenance
- / Software-functions: bore-to-bore/race-track/automatic centering
- / Software-function: rectangle (optional)
- / Datalogger – actual value recording of welding data (optional)
- / Dataviewer – data analysis of datalogger from external PC (optional)
- / Cabinet climatisation (optional)



/ Visualisation

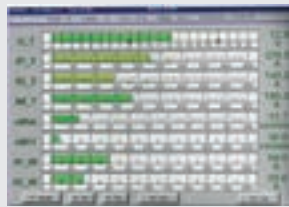

/ Limits – actual value display

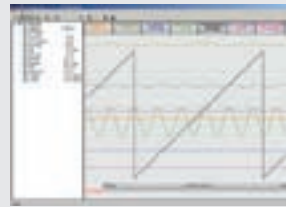

/ Datalogger (optional)



/ Remote maintenance

HMI-RC REMOTE CONTROL

/ Operating, visualisation, parameter correction – easy on location.

The ergonomic and robust remote control provides access to all relevant functions. Due to compact and light design the remote control fits the hand comfortably.



FEATURES

- / Light and robust housing
- / 3,4" color display
- / Emergency stop and 3-step enabling switch
- / 23 functional buttons with LED lighting
- / Exchangeable labeling stripes
- / Connection cable 10 m (393.7 in)
- / Plug & Play

ENDLESS ROTATING WELDING HEAD ETR

/ The core component of the ETR system is the rotating welding head. The torch and wire feeder rotate around the bore axis. Welding current, gas, torch cooling and electrical control signals are transferred without interruption by the transfer module.

Based on requirement, the ETR torch can be extended using the "small/large extension" or "swivel adapter."

/ TWIN WIRE SETUP (OPTIONAL)

TRANSFER MODULE

/ For efficient signal transfer throughout the rotational movement, this module is equipped with maintenance-free, high-quality gold plated slip rings.

WIRE SPOOLS

/ Rotating wire spool. Two wire spools are mounted when using TWIN wire setup.

WIRE FEEDER

/ 4-wheel wire feeder ensures reliable frictionless wire feeding. TWIN setup optional.

SAFETY DOORS

/ Equipped with break-proof glass and emergency switch.

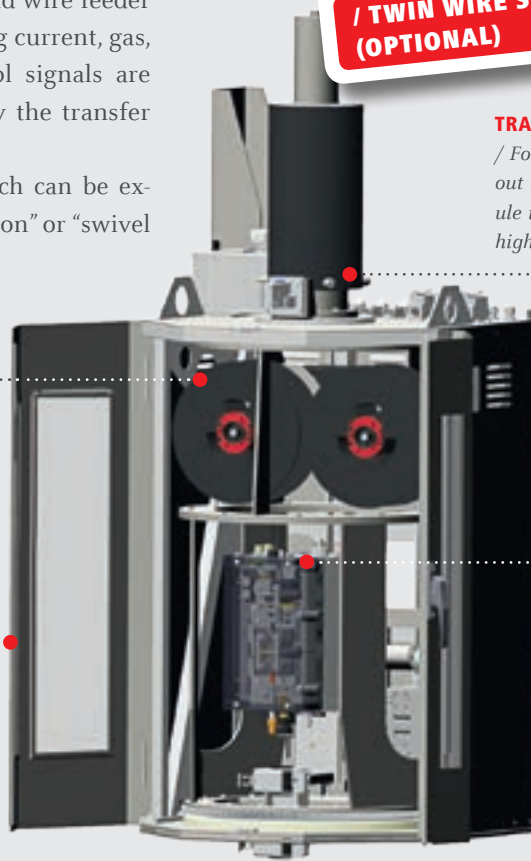

/ TTHW TORCHES

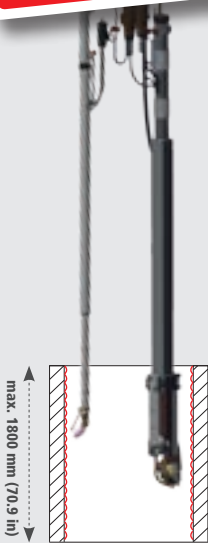

Ø 25 - 320 mm (1 - 12.6 in)

TTHW TORCHES

/ TTHW torches for work piece inside Ø from 25-320 mm (1-12.6 in). Minimum work piece Ø for TTHW 6000M SpeedClad: 150 mm (5,9 in).

/ SMALL EXTENSION



Ø max. 711 mm (28 in)

SMALL EXTENSION

/ TTW torch with small extension for work piece outside diameter up to 711 mm (28 in).

/ SWIVEL ADAPTER

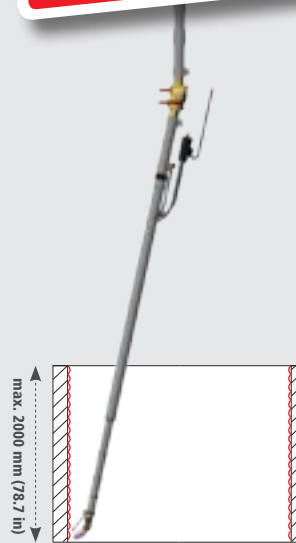

Ø max. 1400 mm (55.1 in)

SWIVEL ADAPTER

/ Swivel adapter with TTHW torch for inside diameter up to 1400 mm (55.1 in).

/ LARGE EXTENSION

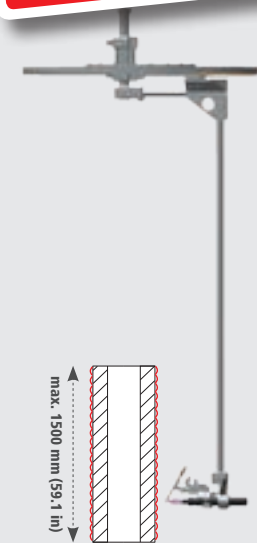

Ø max. 500 mm (19.7 in)

LARGE EXTENSION

/ TTW torch with large extension for work piece outside diameter up to 500 mm (19.7 in).

ETR-S SPEEDCLAD TWIN – A NEW STANDARD IN CLADDING PERFORMANCE

/ SpeedClad Twin combines the advantages of Endless Torch Rotating systems with the fastest cladding process ever. Working three times faster and offering excellent cladding results in a remarkably short time, this equipment will set Fronius users apart from their competition and save substantially on labor and shielding gas costs.

SIGNIFICANT COMPETITIVE ADVANTAGES

/ The new Fronius high-tech cladding system multiplies the efficiency of TIG hotwire welding while maintaining an exceptional quality standard. Using two tungsten cathodes combined with two preheated welding wires for one molten pool allows less penetration while enabling significant faster welding speeds and a much higher deposition rate. Maximum productivity is guaranteed, especially when welding larger components.

SPEEDCLAD TWIN COMPONENTS

/ The SpeedClad Twin torch system is the heart of the SpeedClad Twin process. It is supported by a fully digital and SpeedClad Twin optimized communication system, completed by two additional power sources TransTig 5000 Job and TransTig 2200 Job.

**/ RETROFITABLE ON
EXISTING ETR-SYSTEMS**

SPEEDCLAD TWIN POWER SOURCES SET

/ 2 x TransTig 5000 Job
combined with cooling unit
FK 4000 Rob and
2 x hotwire TransTig 2200 Job.

SYSTEM CONTROLLER FPA 9000

/ High-end system controller
provides SpeedClad Twin soft-
ware configuration.

SPEEDCLAD TWIN TORCH SYSTEM

/ 2 x 300 Ampere, twin
wire application, water-
cooled hotwire feedings,
wear optimized wire
feedings, adjustable torch
head angle.

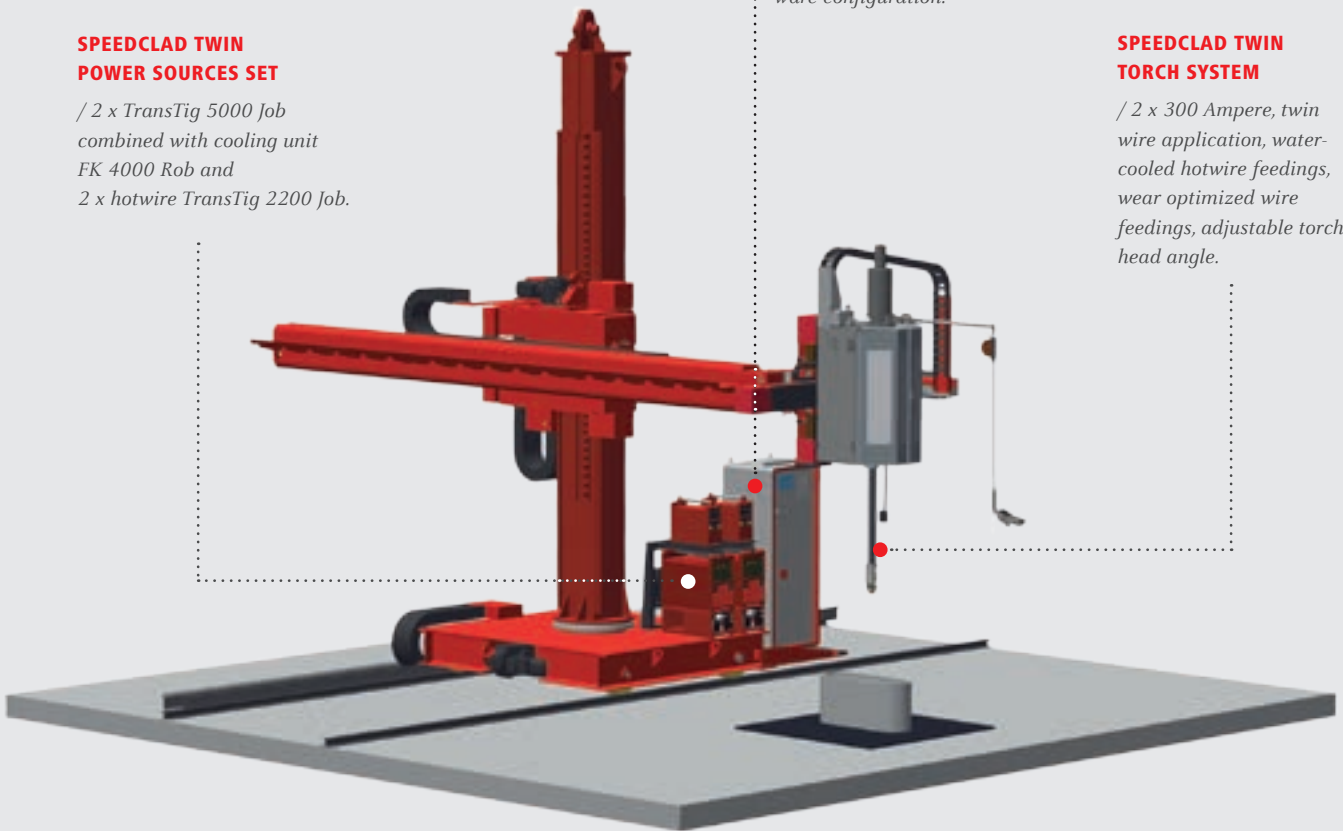

INNOVATIVE TORCH ENGINEERING ACCELERATES AND PERFECTS THE WELDING

/ Matching the same quality as TIG hotwire welding, the SpeedClad Twin cladding solution is both three times faster and even more efficient. Two tungsten electrodes and two preheated welding wires make it possible.

VERSATILE ADJUSTABLE



/ Fronius torch system SpeedClad Twin.

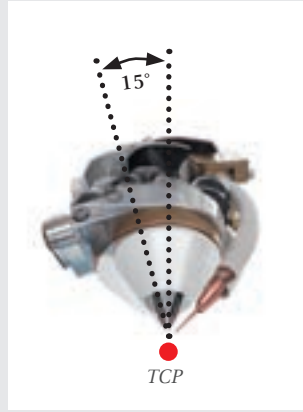

/ Side adjustment, the TCP (Tool Centre Point) stays unchanged.

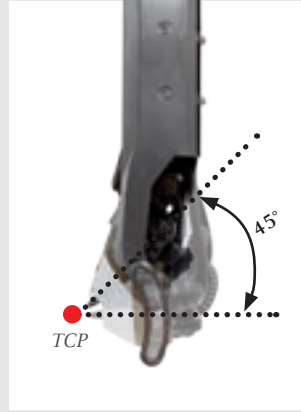

/ Tilt adjustment. The TCP (Tool Centre Point) stays unchanged.

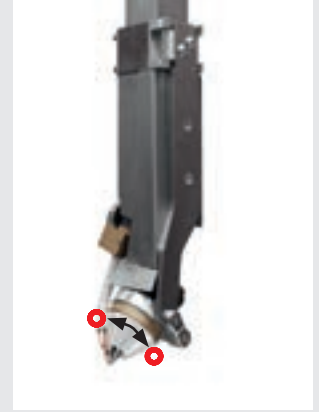

/ Rotatable double electrode.

①

WELDING SPEED*

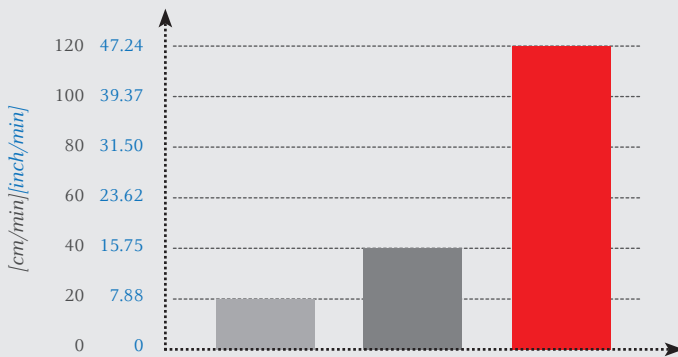

②

DEPOSITION RATE*

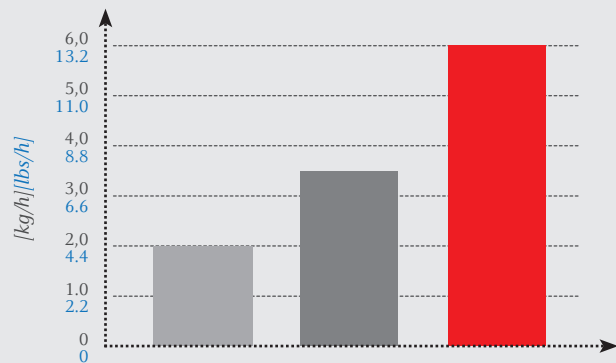

③

GAS CONSUMPTION*

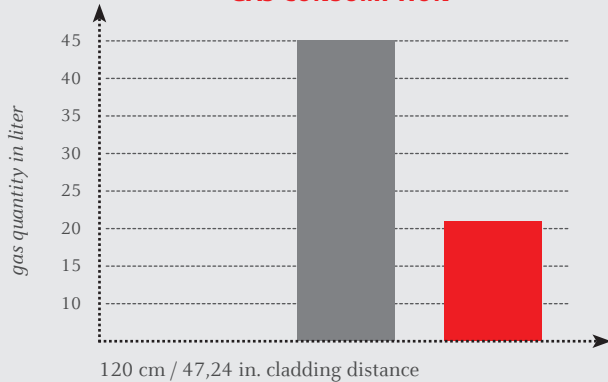

Charts 1+ 2:

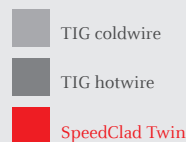

Chart 3:



(*) Depending on application

TECHNICAL DATA

ETR-S / ETR-S SPEEDCLAD	
Mains voltage 50 - 60 Hz (power supply line for the whole system)	3 x 400 V/N/PE
TRANSTIG 5000 JOB	
Welding current 40%/100% DC	500 A/350 A
TRANSTIG 2200 JOB	
Welding current 40%/100% DC	220 A/150 A
DIMENSIONS*	
Length	7000 mm (275.6 in)
Width	3000 mm (118.1 in)
Height	6100 mm (240.2 in)

* According to the standard configuration below – based on the configuration, dimensions can vary.

STANDARD CONFIGURATION (VARIATIONS POSSIBLE)

COMPONENTS

/ FCB 3000-3000/ML700/ETR 50/60Hz
 / FCS 2000-1000/ML375
 / FRT 5000 H/C/FPA
 / TTHW5000M ø125 ETR F++/1,8m ABL
 / ETR-S 25-320/TIG HW
 / FPA 9000/ETR TIG HW system controller
 / TransTig 5000 Job G/F
 / TransTig 2200 Job G/F

SPEEDCLAD TWIN CONFIGURATION (VARIATIONS POSSIBLE)

COMPONENTS

/ FCB 3000-3000/ML700/ETR 50/60Hz
 / FCS 2000-1000/ML375
 / FRT 5000 H/C/FPA
 / TTHW6000M SpeedClad ø150 F++/1,8m ABL
 / ETR-S 25-320/TIG HW
 / FPA 9000/ETR TIG HW SpeedClad Twin optimized system controller
 / 2 x TransTig 5000 Job G/F
 / 2 x TransTig 2200 Job G/F

WORK PIECE GEOMETRIES

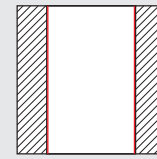

/ Cylindric bore

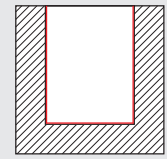

/ Cylindric bore with base

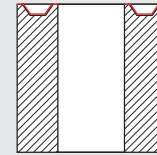

/ Ring groove

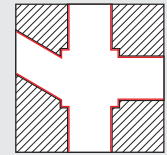

/ Bore-to-bore advanced

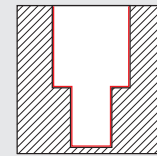

/ Cylindric bore – multiple diameters

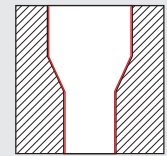

/ Cylindric and conical bore

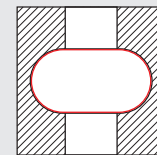

/ Race-track

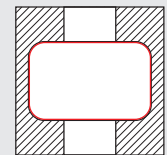

/ Rectangle (optional)

/ Perfect Welding / Solar Energy / Perfect Charging

WE HAVE THREE DIVISIONS AND ONE PASSION: SHIFTING THE LIMITS OF POSSIBILITY.

/ Whether welding technology, photovoltaics or battery charging technology – our goal is clearly defined: to be the innovation leader. With around 3,700 employees worldwide, we shift the limits of what's possible - our record of over 800 granted patents is testimony to this. While others progress step by step, we innovate in leaps and bounds. Just as we've always done. The responsible use of our resources forms the basis of our corporate policy.

Further information about all Fronius products and our global sales partners and representatives can be found at www.fronius.com

v06 Apr 2016 EN

Fronius Canada Ltd.
 2875 Argentia Road, Units 4,5 & 6
 Mississauga, ON L5N 8G6
 Canada
 Telephone +1 905 288-2100
 Fax +1 905 288-2101
sales.canada@fronius.com
www.fronius.ca

Fronius USA LLC
 6797 Fronius Drive
 Portage, IN 46368
 USA
 Telephone +1 877 FRONIUS
sales.usa@fronius.com
www.fronius-usa.com

Fronius UK Limited
 Maidstone Road, Kingston
 Milton Keynes, MK10 0BD
 United Kingdom
 Telephone +44 1908 512 300
 Fax +44 1908 512 329
info-uk@fronius.com
www.fronius.co.uk

Fronius International GmbH
 Froniusplatz 1
 4600 Wels
 Austria
 Telephone +43 7242 241-0
 Fax +43 7242 241-953940
sales@fronius.com
www.fronius.com